

EMC Test Report

Applicant's Name.....: **Zhongshan Kerisheng supply chain Management Co., LTD**
Applicant: Card 04, 33rd Floor, Lihe Commercial Center, 98 Tongxing Road, Guzhen Town, Zhongshan City
Manufacturer's Name: **Zhongshan Kerisheng supply chain Management Co., LTD**
Address: Card 04, 33rd Floor, Lihe Commercial Center, 98 Tongxing Road, Guzhen Town, Zhongshan City

Product Description:

Product Name.....: LED bracket light

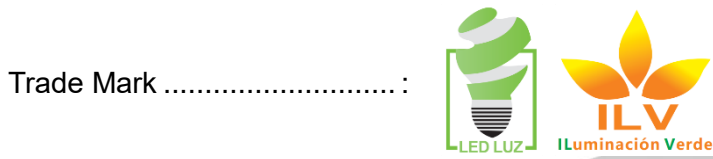

Model Name: JH-07V-0100-01A (Additional models are shown in the attached table 2.1.1)

Standards.....: EN IEC 55015:2019+A11:2020
EN IEC 61547:2023
EN IEC 61000-3-2:2019+A1:2021
EN 61000-3-3:2013+A2:2021

This device described above has been tested by Promise, and the test results show that the equipment under test (EUT) is in compliance with the EMC Directive 2014/30/EU requirements. And it is applicable only to the tested sample identified in the report.

This report shall not be reproduced except in full, without the written approval of Promise, this document may be altered or revised by Promise personnel, and shall be noted in the revision of the document.

Date of Test:

Date (s) of Performance of Tests.....: Apr. 23, 2025 ~ Apr. 25, 2025

Date of Issue.....: Apr. 25, 2025

Test Result.....: **Pass**

Prepared By : 

(Stephen Tan)

Reviewed by : 

(Chopin Xiao)

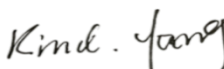
Approved by : 

(Kind yang)

Report Revise Record

Report Version	Revise Time	Issued Date	Valid Version	Notes
V1.0	/	Apr. 25, 2025	Valid	Original Report



TABLE OF CONTENTS

1 . TEST SUMMARY	4
2. GENERAL INFORMATION	5
2.1 GENERAL DESCRIPTION OF THE EUT	5
2.2 DESCRIPTION OF THE TEST MODES	7
2.3 TEST CONFIGURATION DIAGRAM	7
2.4 DESCRIPTION TEST PERIPHERAL AND EUT PERIPHERAL	8
2.5 LABORATORY INFORMATION	9
2.6 MEASUREMENT UNCERTAINTY	9
2.7 MEASUREMENT INSTRUMENTS LIST	10
3.3 HARMONICS CURRENT	23
3.4 VOLTAGE FLUCTUATION AND FLICKERS	26
4. EMC IMMUNITY TEST	28
4.1 STANDARD COMPLIANCE/SERVIRITY LEVEL/CRITERIA	28
4.2 GENERAL PERFORMANCE CRITERIA	29
4.3 ELECTROSTATIC DISCHARGE IMMUNITY TEST (ESD)	30
4.4 RADIATED, RADIO-FREQUENCY, ELECTROMAGNETIC FIELD IMMUNITY TEST (RS)	34
4.5 ELECTRICAL FAST TRANSIENT (EFT)	37
4.6 SURGE TESTING	41
4.7 CONDUCTED RADIO FREQUENCY DISTURBANCES (CS)	44
4.8 VOLTAGE INTERRUPTION/DIPS TESTING (DIPS)	47
APPENDIX 1- TEST SETUP	49
APPENDIX 2-PHOTOGRAPHS OF EUT CONSTRUCTIONAL DETAILS	52

1. TEST SUMMARY

Test procedures according to the technical standards:

EMC Emission				
Standard	Test Item	Limit	Judgment	Remark
EN IEC 55015:2019+A11:2020	Conducted Emission on AC and Telecom Port 150kHz to 30MHz	-----	PASS	
	Radiated Emission	-----	PASS	
	Magnetic field radiation harassment	-----	PASS	
EN IEC 61000-3-2:2019+A1:2021	Harmonic Current Emission	C	PASS	
EN 61000-3-3:2013+A2:2021	Voltage Fluctuations & Flicker	-----	PASS	
EMC Immunity				
Section EN IEC 61547:2023	Test Item	Performance Criteria	Judgment	Remark
EN 61000-4-2:2009	Electrostatic discharges	B	PASS	
EN 61000-4-3:2006+A1:2008+A2:2010	Continuous RF electromagnetic field disturbances	A	PASS	
EN 61000-4-4:2012	Electrical fast transients/burst	B	PASS	
EN 61000-4-5:2014+A1:2017	Surges	B	PASS	
EN 61000-4-6:2014+AC:2015	Continuous induced RF disturbances	A	PASS	
EN 61000-4-11:2004+A1:2017	Voltage dips and interruptions	B / C	PASS	NOTE (2)

NOTE:



(1) "N/A" denotes test which is not applicable in this Test Report

(2) Voltage Dip: 100% reduction – Performance Criteria **B**

Voltage Dip: 30% reduction – Performance Criteria **C**

2. GENERAL INFORMATION

2.1 GENERAL DESCRIPTION OF THE EUT

Product Name	LED bracket light
Trade Mark	 
Model Name	JH-07V-0100-01A (Additional models are shown in the attached table 2.1.1)
Model Distinction	All models except model name and appearance color, The internal structure is the same as the circuit.
Sampling model	JH-07V-0100-01A
Test Sample Number	PRMS2504341A01
Product Description	The EUT is a LED bracket light More details of EUT technical specification, please refer to the User's Manual.
Power Source	Input: 100-277 V~ 50/60Hz 100W
EUT Highest internal frequency:	<input checked="" type="checkbox"/> $F_x \leq 108\text{MHz}$ <input type="checkbox"/> $108 < F_x \leq 500\text{MHz}$ <input type="checkbox"/> $500\text{MHz} < F_x \leq 1\text{GHz}$ <input type="checkbox"/> $F_x > 1\text{GHz}$
Hardware Version Number	N/A
Software Version Number	N/A

2.1.1 Serial Model Name see below table for details :

No.	Model No.	Power	No.	Model No.	Power
1	DG-07U-0018-01A	18W	17	JH-02V-0040-01A	40W
2	DG-01V-0020-01A	20W	18	JH-05V-0040-01A	40W
3	DG-02V-0020-01A	20W	19	DZ-01V-0040-01A	40W
4	DG-07V-0020-01A	20W	20	DG-10V-0030-01A	30W
5	DG-08V-0020-01A	20W	21	DG-09V-0030-01A	30W
6	DG-01V-0040-01A	40W	22	JH-03V-0030-01A	30W
7	DG-02V-0040-01A	40W	23	JH-04V-0030-01A	30W
8	DG-06V-0040-01A	40W	24	JH-03V-0050-01A	50W
9	DG-11V-0040-01A	40W	25	JH-04V-0050-01A	50W
10	DG-03V-0030-01A	30W	26	DG-12V-0010-01A	10W
11	DG-04V-0030-01A	30W	27	DG-12V-0020-01A	20W
12	DG-13V-0009-01A	9W	28	DG-04V-0030-01A	30W
13	DG-13V-0018-01A	18W	29	ZJ-01V-0020-01A	20W
14	DG-14V-0009-01A	9W	30	JH-06V-0040-01A	40W
15	DG-14V-0018-01A	18W	31	JH-07V-0050-01A	50W
16	JH-01V-0040-01A	40W	32	JH-07V-0080-01A	80W

2.2 DESCRIPTION OF THE TEST MODES

characteristics generation from EUT, the test system was pre scanned and was tested on the basis of the consideration of the following EUT operation mode or test configuration mode which possibly have an effect on EMI emission level.

Pretest Mode	Description
Mode 1	Lighting Mode

For Radiated Test	
Final Test Mode	Description
Mode 1	Lighting Mode

For EMS Test	
Final Test Mode	Description
Mode 1	Lighting Mode

Note:

N/A

2.3 TEST CONFIGURATION DIAGRAM

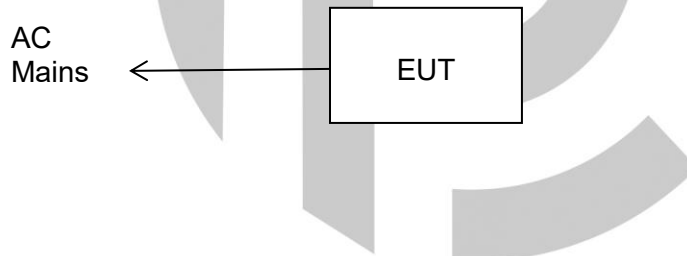

2.4 DESCRIPTION TEST PERIPHERAL AND EUT PERIPHERAL

The EUT has been tested as an independent unit together with other necessary accessories or support units. The following support units or accessories were used to form a representative test configuration during the tests.

Accessories equipment

Item	Equipment	Manufacturer	Model No.	Serial No.	Power Cord
N/A	N/A	N/A	N/A	N/A	N/A
/	/	/	/	/	/

Auxiliary equipment

Item	Equipment	Manufacturer	Model No.	Serial No.	Power Cord
N/A	N/A	N/A	N/A	N/A	N/A
/	/	/	/	/	/

Cable Type

Item	Signal Cable Type	Shielded Type	Ferrite Core	Length
N/A	N/A	N/A	N/A	N/A
/	/	/	/	/

Note:

- (1) The support equipment was authorized by Declaration of Confirmation.
- (2) For detachable type I/O cable should be specified the length in cm in 『Length』 column.
- (3) “YES” means “shielded” “with core”; “NO” means “unshielded” “without core”.

2.5 LABORATORY INFORMATION

Company Name:	Shenzhen Promise Test Technology Co., Ltd.
Address:	103, Building 1, Yibaolai Industrial City, Qiaotou Community, Fuhai Street, Bao'an District, Shenzhen, Guangdong, China
Telephone:	0755-23319501

2.6 MEASUREMENT UNCERTAINTY

The reported uncertainty of measurement $y \pm U$, where expanded uncertainty U is based on a standard uncertainty multiplied by a coverage factor of $k=2$, providing a level of confidence of approximately **95 %**.

A. Conducted Measurement:

Test Site	Method	Measurement Frequency Range	U · (dB)	NOTE
Conducted Emission	CISPR 16-4-2	9kHz ~ 30MHz	2.83	
		0.15MHz ~ 30MHz	2.90	

B. Radiated Measurement:

Test Site	Method	Measurement Frequency Range	U · (dB)	NOTE
Radiated Emission	CISPR 16-4-2	30MHz ~ 1000MHz	5.19	

2.7 MEASUREMENT INSTRUMENTS LIST

2.7.1 CONDUCTED TEST SITE

Conducted Emission Test					
Equipment	Manufacturer	Model#	Serial#	Last Cal.	Next Cal
843 Shielded Room	ChengYu	843 Room	843	May. 20, 2021	May. 19, 2025
EMI Receiver	R&S	ESCI3	100306	May. 11, 2024	May. 10, 2025
LISN	ETS-LINDGREN	3810/2	00045732	May. 11, 2024	May. 10, 2025
Attenuator	SUHNER	ESH3-Z2	100243	May. 11, 2024	May. 10, 2025
843 Cable 1#	FUJIKURA	843C1#	001	May. 11, 2024	May. 10, 2025
Test software	FALA	EZ-EMC	EMC-CON3A1.1		--

Radiation Emission Test					
Equipment	Manufacturer	Model#	Serial#	Last Cal.	Next Cal.
966 chamber	ChengYu	966 Room	966	May. 20, 2021	May. 19, 2025
Spectrum Analyzer	Agilent	N9020A	MY544440442	May. 11, 2024	May. 10, 2025
Low-Noise Amplifier	HEWLETT PACKARD	8447D	2727A05439	May. 11, 2024	May. 10, 2025
Log-periodic Antenna	SunAR	JB6	A121411	May. 11, 2023	May. 10, 2025
EMI Receiver	R&S	ESCI3	100306	May. 11, 2024	May. 10, 2025
966 Cable 1#	CHENGYU	966	003	May. 11, 2024	May. 10, 2025
Test software	FALA	EZ-EMC	FA-03A2 RE+		--

Radiated Disturbances Measurement at Frequencies Between 0.009 MHz to 30 MHz					
Equipment	Manufacturer	Model#	Serial#	Last Cal.	Next Cal.
Three-loop antenna	/	RF300	/	May. 11, 2024	May. 10, 2025
EMI Receiver	R&S	ESCI	/	May. 11, 2024	May. 10, 2025
LISN	EMCO	ENV216	/	May. 11, 2024	May. 10, 2025
CABLE	/	CE01	/	May. 11, 2024	May. 10, 2025

Harmonic/Flicker Test					
Equipment	Manufacturer	Model#	Serial#	Last Cal.	Next Cal.
Harmonic & Voltage Flicker	LAPLACE	AC 2000A	--	May. 11, 2024	May. 10, 2025
AC Power Source	LAPLACE	DAL40	10003021350179	May. 11, 2024	May. 10, 2025
Testing Software	HTEC	V1.5	--	--	--

For Electrostatic Discharge/ Electrical Fast Transients/ Voltage Dips and Interruptions Test					
Equipment	Manufacturer	Model#	Serial#	Last Cal.	Next Cal.
Combined interference generator	Prima	EED2005TG	PR210554993	May. 11, 2024	May. 10, 2025
Capacitive coupling clamp	Prima	EFT-CLAMP	EFT-198	May. 11, 2024	May. 10, 2025
ESD generator	Prima	EED2005TG	PR210554993	May. 11, 2024	May. 10, 2025

For Surges Test					
Equipment	Manufacturer	Model#	Serial#	Last Cal.	Next Cal.
Lightning surge generator	Prima	SUG61005TB	PR210554993	May. 11, 2024	May. 10, 2025

Immunity to conducted disturbances, induced by radio-frequency fields (CS)					
Equipment	Manufacturer	Model#	Serial#	Last Cal.	Next Cal.
Conducted Immunity Test System	Schloder	CDG-7000-75	126B129012014	May. 11, 2024	May. 10, 2025
CDN	Schloder	CNDM2+M3-16	N/A	May. 11, 2024	May. 10, 2025
EM-Clamp	Schloder	EMCL-20	132A1194/2014	May. 11, 2024	May. 10, 2025
RF Attenuator	Schloder	75w 6dB	N/A	May. 11, 2024	May. 10, 2025

Radiated, radio-frequency, electromagnetic field immunity (RS)					
Equipment	Manufacturer	Model#	Serial#	Last Cal.	Next Cal.
Antenna	SKET	STLP 9129_Plus	/	/	/
Signal Generator	Agilent	N5181A	MY50141997	Jan. 21, 2025	Jan. 20, 2026
Amplifier	SKET	HAP_80M01G-250W	202105183	Jun. 27, 2024	Jun. 26, 2025
Amplifier	SKET	HAP_03G06G-80W	202305501	Jun. 27, 2024	Jun. 26, 2025
Field Probe	Narda	EP-601	811ZX01057	Jun. 29, 2024	Jun. 28, 2025
USB Power Sensor	Agilent	U2001A	MY53410013	Jan. 21, 2025	Jan. 20, 2026
USB Power Sensor	Agilent	U2001A	MZ54330012	Jan. 21, 2025	Jan. 20, 2026



3. EMC EMISSION TEST

3.1 CONDUCTED EMISSION MEASUREMENT

3.1.1 POWER LINE CONDUCTED EMISSION

(Frequency Range 9KHz-30MHz)

FREQUENCY (MHz)	Maximum RF Line Voltage	
	Quasi-peak	Average
0.009-0.05	110	---
0.05-0.15	90 - 80 *	---
0.15 -0.50	66 - 56 *	56 - 46 *
0.50 -5.0	56.00	46.00
5.0 -30.0	60.00	50.00

Note: (1) The tighter limit applies at the band edges.

(2) The limit of " * " marked band means the limitation decreases linearly with the logarithm of the frequency in the range.

(Frequency Range 150KHz-30MHz)

3.1.2 LOAD TERMINAL CONDUCTED EMISSION

FREQUENCY (MHz)	Maximum RF Line Voltage	
	Quasi-peak	Average
0.15 -0.50	80	70
0.50 -30.0	74	64

Note: (1) The tighter limit applies at the band edges.

3.1.3 CONTROL TERMINAL CONDUCTED EMISSION (Frequency Range 150KHz-30MHz)

FREQUENCY (MHz)	Maximum RF Line Voltage	
	Quasi-peak	Average
0.15 -0.50	84 - 74*	74 - 64*
0.50 -30.0	74	64

Note: (1) The tighter limit applies at the band edges.

(2) The limit of " * " marked band means the limitation decreases linearly with the logarithm of the frequency in the range.

The following table is the setting of the receiver

Receiver Parameters	Setting
Attenuation	10 dB
Start Frequency	0.009 MHz
Stop Frequency	30 MHz
IF Bandwidth	200Hz and 9 kHz

3.1.4 TEST PROCEDURE

- a. The EUT was placed 0.4 meters from the conducting wall of the shielded room with EUT being connected to the power mains through a line impedance stabilization network (LISN). Other support units were connected to the power mains through another LISN. The two LISNs provide 50 Ohm/ 50uH of coupling impedance for the measuring instrument.
- b. Interconnecting cables that hang closer than 40 cm to the ground plane shall be folded back and forth in the center forming a bundle 30 to 40 cm long.
- c. I/O cables that are not connected to a peripheral shall be bundled in the center. The end of the cable may be terminated, if required, using the correct terminating impedance. The overall length shall not exceed 1 m.
- d. For the actual test configuration, please refer to the related Item –EUT Test Photos.

3.1.5 TEST SETUP

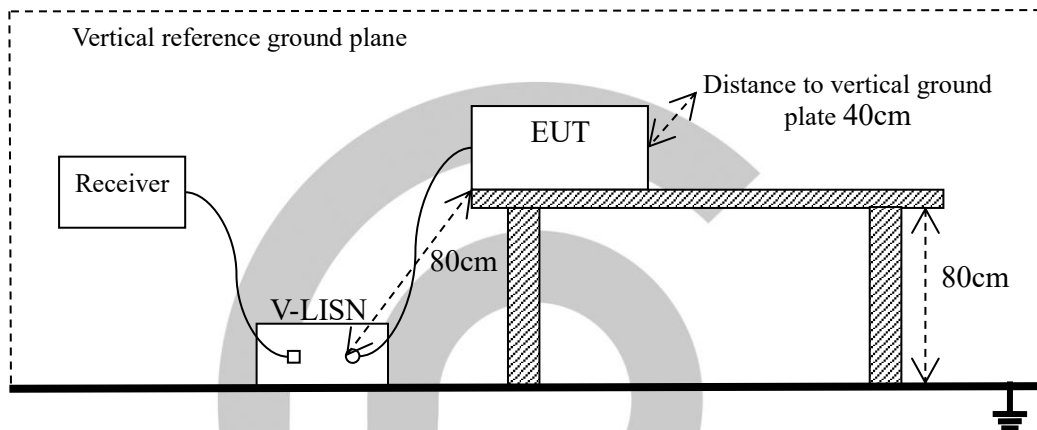

3.1.6 EUT OPERATING CONDITIONS

The EUT tested system was configured as the statements of 2.3 Unless otherwise a special operating condition is specified in the following during the testing.

3.1.7 TEST RESULTS

Temperature:	25.8°C	Relative Humidity:	54%
Phase:	L	Test Mode:	Mode 1
Test Voltage:	AC 230V 50Hz	Test Date:	2025.04.23

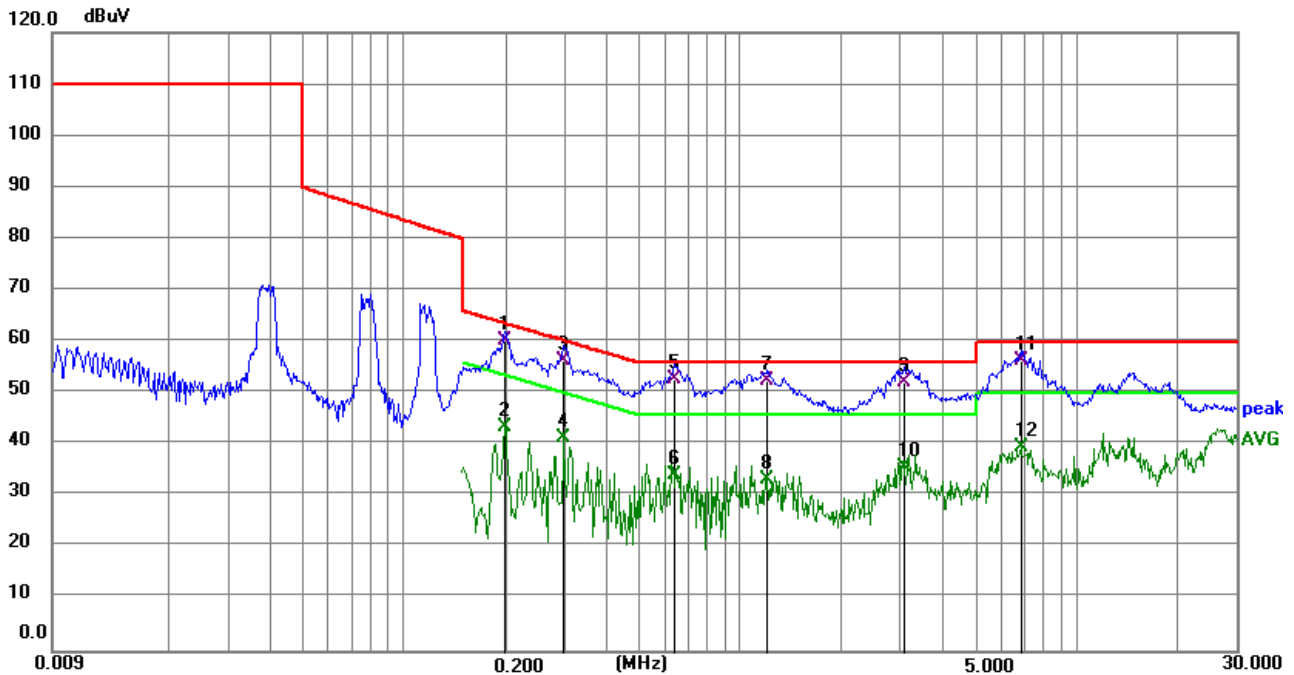

No.	Frequency (MHz)	Reading (dBuV)	Correct Factor (dB)	Result (dBuV)	Limit (dBuV)	Margin (dB)	Detector
1	0.1995	50.28	9.93	60.21	63.63	-3.42	QP
2	0.1995	33.59	9.93	43.52	53.63	-10.11	AVG
3	0.2983	46.62	9.92	56.54	60.29	-3.75	QP
4	0.2983	31.57	9.92	41.49	50.29	-8.80	AVG
5	0.6401	43.01	9.90	52.91	56.00	-3.09	QP
6	0.6401	24.47	9.90	34.37	46.00	-11.63	AVG
7	1.2157	42.60	9.91	52.51	56.00	-3.49	QP
8	1.2157	23.52	9.91	33.43	46.00	-12.57	AVG
9	3.1199	42.39	9.96	52.35	56.00	-3.65	QP
10	3.1199	25.74	9.96	35.70	46.00	-10.30	AVG
11	6.8596	46.35	10.13	56.48	60.00	-3.52	QP
12	6.8596	29.57	10.13	39.70	50.00	-10.30	AVG

Remark:

1. All readings are Quasi-Peak and Average values
2. Margin = Result (Result = Reading + Factor) - Limit
3. Factor = Insertion loss + Cable loss

Temperature:	25.8°C	Relative Humidity:	54%
Phase:	N	Test Mode:	Mode 1
Test Voltage:	AC 230V 50Hz	Test Date:	2025.04.23

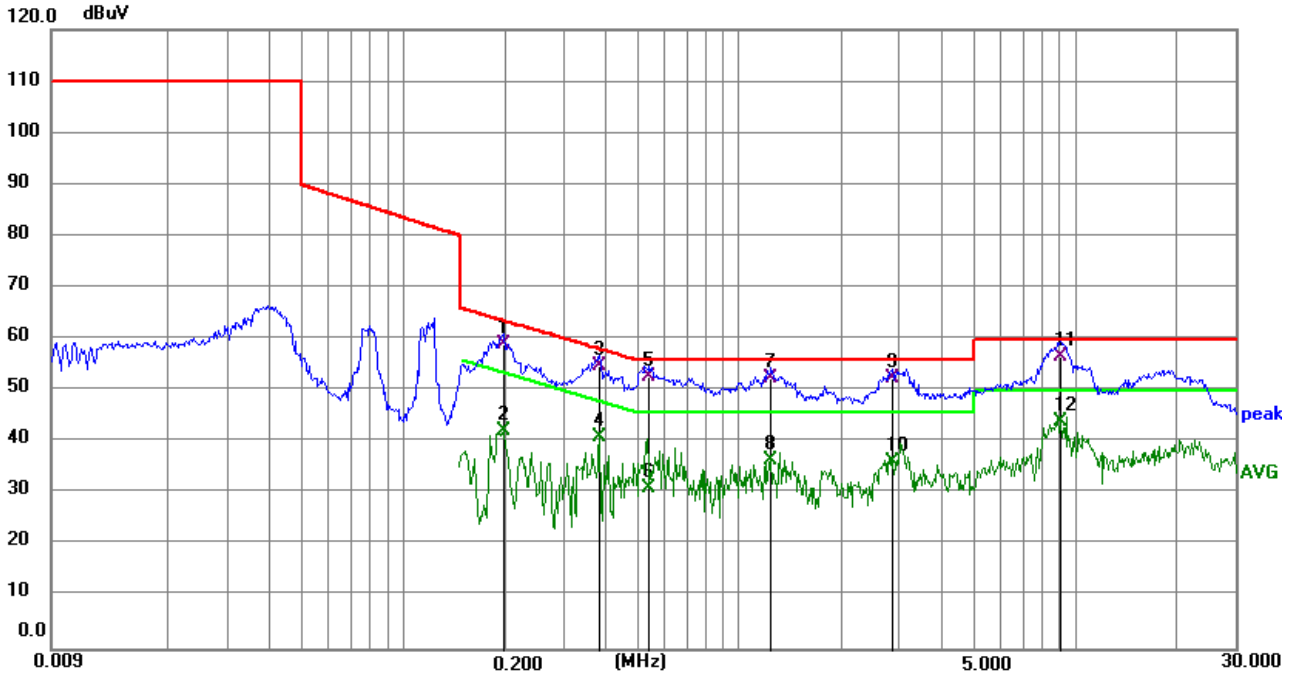

No.	Frequency (MHz)	Reading (dBuV)	Factor (dB)	Level (dBuV)	Limit (dBuV)	Margin (dB)	Detector
1	0.1995	49.22	9.93	59.15	63.63	-4.48	QP
2	0.1995	32.30	9.93	42.23	53.63	-11.40	AVG
3	0.3840	45.05	9.91	54.96	58.19	-3.23	QP
4	0.3840	31.28	9.91	41.19	48.19	-7.00	AVG
5	0.5413	42.97	9.91	52.88	56.00	-3.12	QP
6	0.5413	21.51	9.91	31.42	46.00	-14.58	AVG
7	1.2560	42.71	9.91	52.62	56.00	-3.38	QP
8	1.2560	26.65	9.91	36.56	46.00	-9.44	AVG
9	2.8635	42.42	9.95	52.37	56.00	-3.63	QP
10	2.8635	26.54	9.95	36.49	46.00	-9.51	AVG
11	9.0960	46.26	10.32	56.58	60.00	-3.42	QP
12	9.0960	33.77	10.32	44.09	50.00	-5.91	AVG

Remark:

1. All readings are Quasi-Peak and Average values
2. Margin = Level (Level = Reading + Factor) - Limit
3. Factor = Insertion loss + Cable loss

3.2.3 TEST SETUP

(A) Radiated Emission Test Set-Up Frequency Below 30 MHz

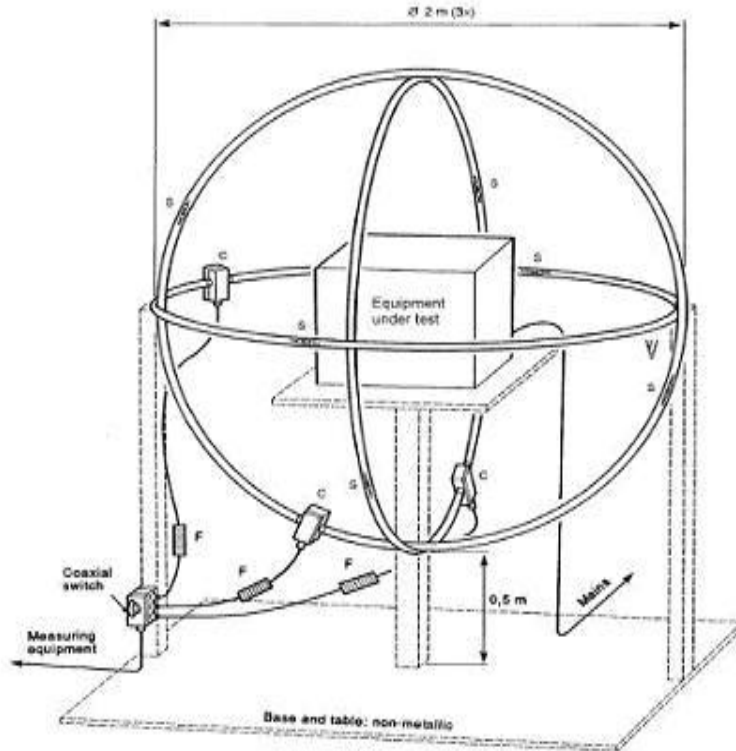

(B) Radiated Emission Test Set-Up Frequency Below 30 MHz

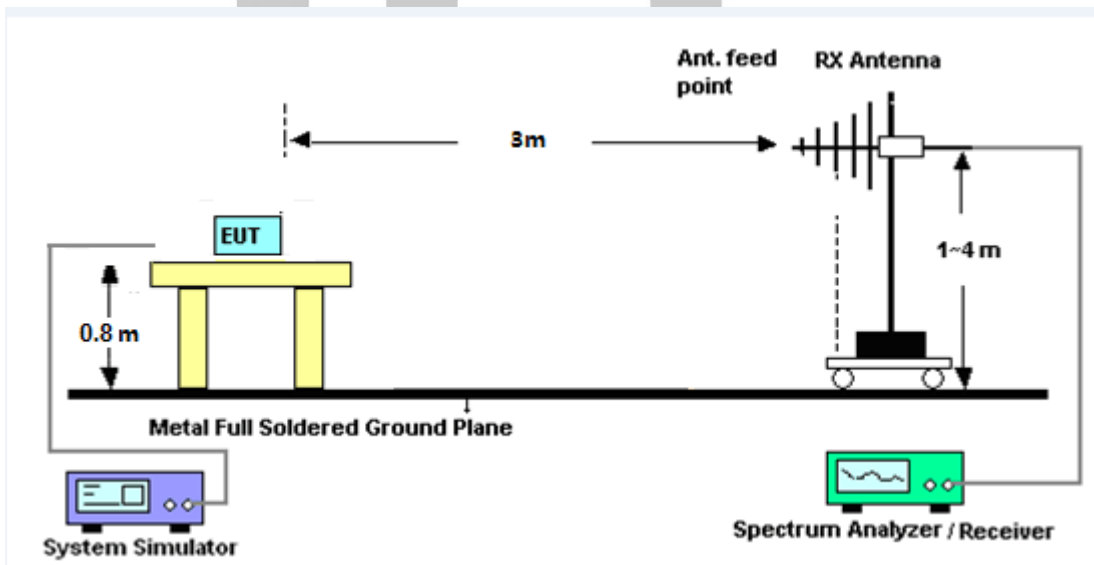

3.2.4 EUT OPERATING CONDITIONS

The EUT tested system was configured as the statements of 2.3 Unless otherwise a special operating condition is specified in the following during the testing.

3.2.5 TEST RESULTS (30MHz-300MHz)

Temperature:	25.2°C	Relative Humidity:	50%
Phase:	Horizontal	Test Mode:	Mode 1
Test Voltage:	AC 230V 50Hz	Test Date:	2025.04.23

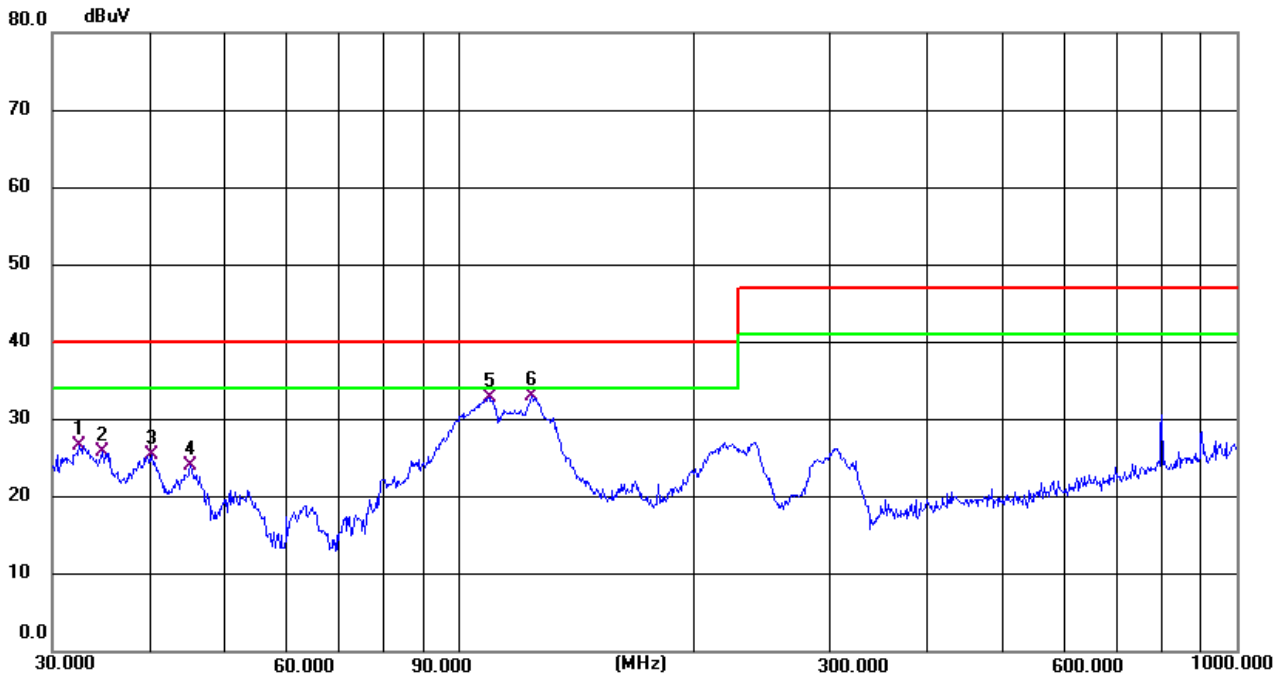

No.	Frequency (MHz)	Reading (dBuV)	Correct Factor (dB)	Results (dBuV/m)	Limit (dBuV/m)	Margin (dB)	Detector
1	32.5197	33.43	-6.77	26.66	40.00	-13.34	QP
2	34.8821	34.28	-8.54	25.74	40.00	-14.26	QP
3	40.2754	35.14	-9.77	25.37	40.00	-14.63	QP
4	45.2165	39.43	-15.40	24.03	40.00	-15.97	QP
5	109.0285	46.52	-13.73	32.79	40.00	-7.21	QP
6	124.1329	45.07	-12.14	32.93	40.00	-7.07	QP

Remark:

1. All readings are Quasi-Peak
2. Margin = Result (Result = Reading + Factor) – Limit
3. Factor = Cable Loss + Antenna Factor – Amplifier Gain

Temperature:	25.2°C	Relative Humidity:	50%
Phase:	Vertical	Test Mode:	Mode 1
Test Voltage:	AC 230V 50Hz	Test Date:	2025.04.23

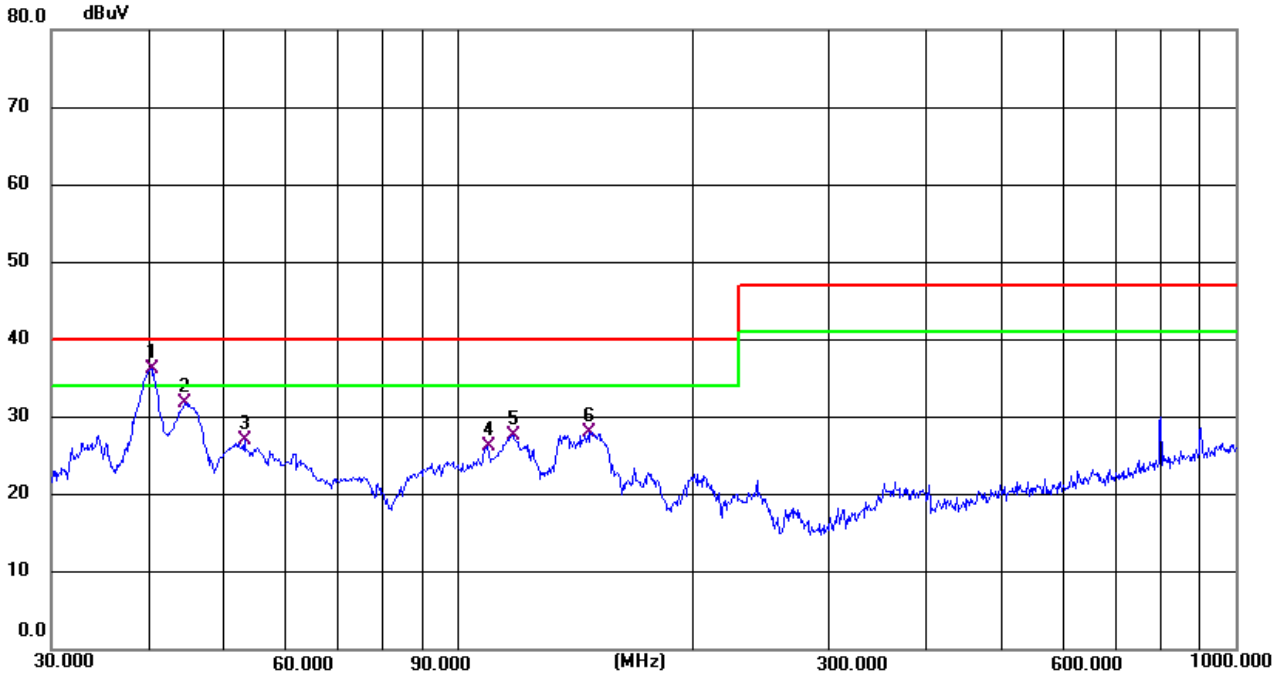

No.	Frequency (MHz)	Reading (dBuV)	Correct Factor (dB)	Results (dBuV/m)	Limit (dBuV/m)	Margin (dB)	Detector
1	40.4170	46.36	-10.10	36.26	40.00	-3.74	QP
2	44.5867	46.87	-14.96	31.91	40.00	-8.09	QP
3	53.1313	45.17	-18.20	26.97	40.00	-13.03	QP
4	109.0285	39.98	-13.73	26.25	40.00	-13.75	QP
5	117.7724	40.22	-12.56	27.66	40.00	-12.34	QP
6	147.9214	41.53	-13.45	28.08	40.00	-11.92	QP

Remark:

1. All readings are Quasi-Peak
2. Margin = Result (Result = Reading + Factor) - Limit
3. Factor = Cable Loss + Antenna Factor - Amplifier Gain

3.2.6 TEST RESULTS (0.009~30MHz)

Temperature:	25.3℃	Relative Humidity:	54%
Test Voltage:	AC 230V 50Hz	Test Date:	2025.04.23
Test Mode:	Mode 1	Polarization:	X

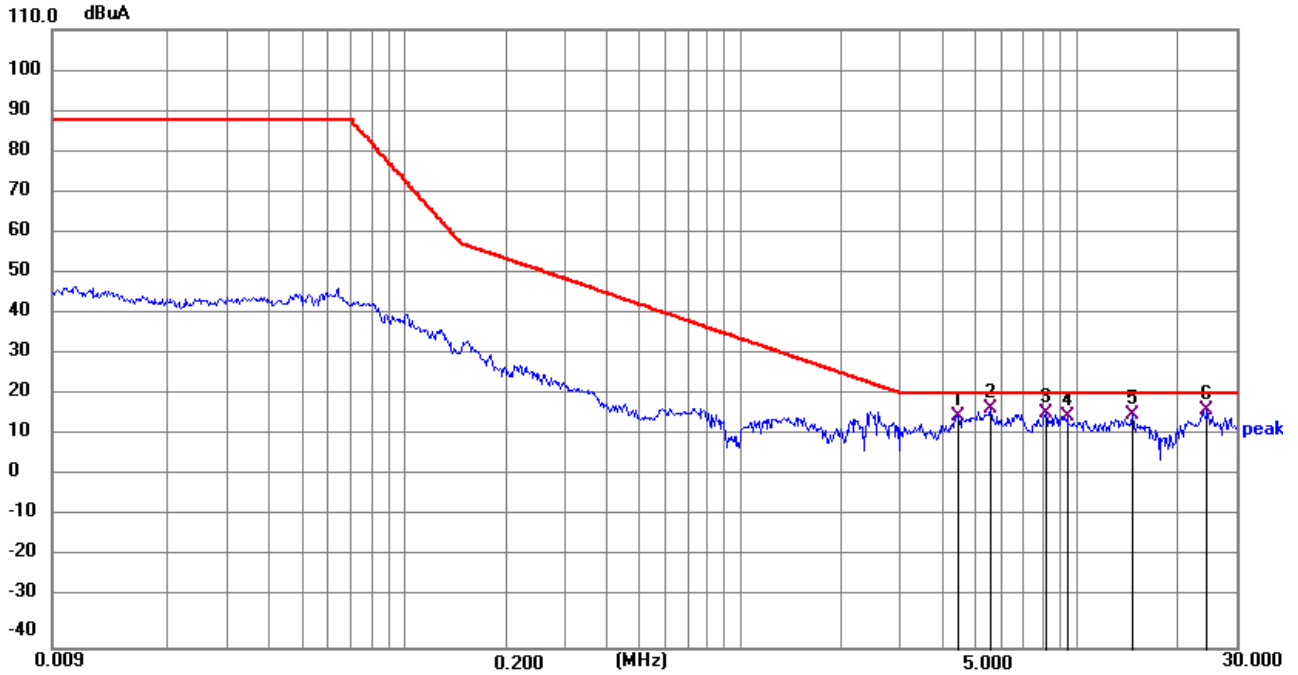

No.	Frequency (MHz)	Reading (dBuA)	Correct Factor (dB)	Results (dBuA)	Limit (dBuA)	Margin (dB)	Detector
1	4.4744	8.10	8.36	16.46	22.00	-5.54	QP
2	5.5678	10.35	7.97	18.32	22.00	-3.68	QP
3	8.1326	8.25	8.61	16.86	22.00	-5.14	QP
4	9.4740	7.18	9.13	16.31	22.00	-5.69	QP
5	14.7345	9.71	7.02	16.73	22.00	-5.27	QP
6	24.6431	11.57	6.15	17.72	22.00	-4.28	QP

Remark:

1. All readings are Quasi-Peak
2. Margin = Result (Result = Reading + Factor) - Limit
3. Factor = Insertion loss + Cable loss

Temperature:	25.3°C	Relative Humidity:	54%
Test Voltage:	AC 230V 50Hz	Test Date:	2025.04.23
Test Mode:	Mode 1	Polarization:	Y

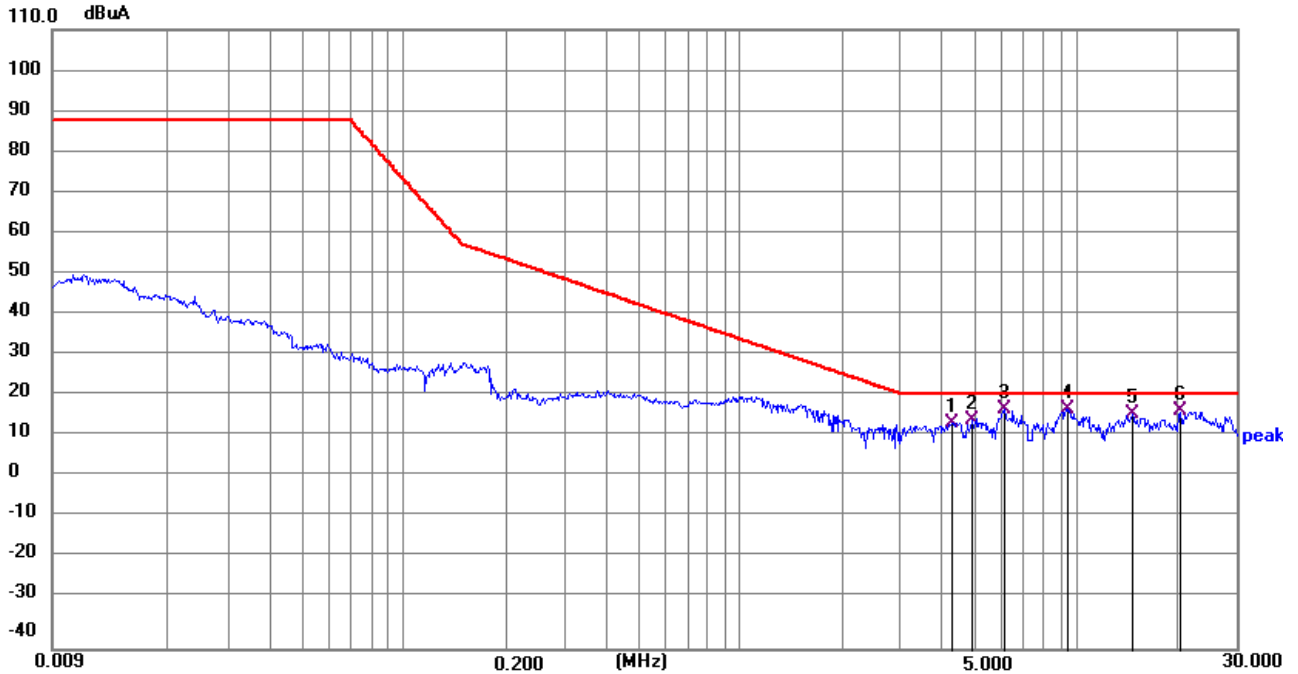

No.	Frequency (MHz)	Reading (dBuA)	Correct Factor (dB)	Results (dBuA)	Limit (dBuA)	Margin (dB)	Detector
1	4.3033	6.39	8.31	14.70	22.00	-7.30	QP
2	4.9200	7.29	8.11	15.40	22.00	-6.60	QP
3	6.1528	10.23	7.76	17.99	22.00	-4.01	QP
4	9.5280	9.17	9.05	18.22	22.00	-3.78	QP
5	14.7972	9.87	6.99	16.86	22.00	-5.14	QP
6	20.5575	12.86	4.75	17.61	22.00	-4.39	QP

Remark:

1. All readings are Quasi-Peak
2. Margin = Result (Result = Reading + Factor) - Limit
3. Factor = Insertion loss + Cable loss

Temperature:	25.3°C	Relative Humidity:	54%
Test Voltage:	AC 230V 50Hz	Test Date:	2025.04.23
Test Mode:	Mode 1	Polarization:	Z

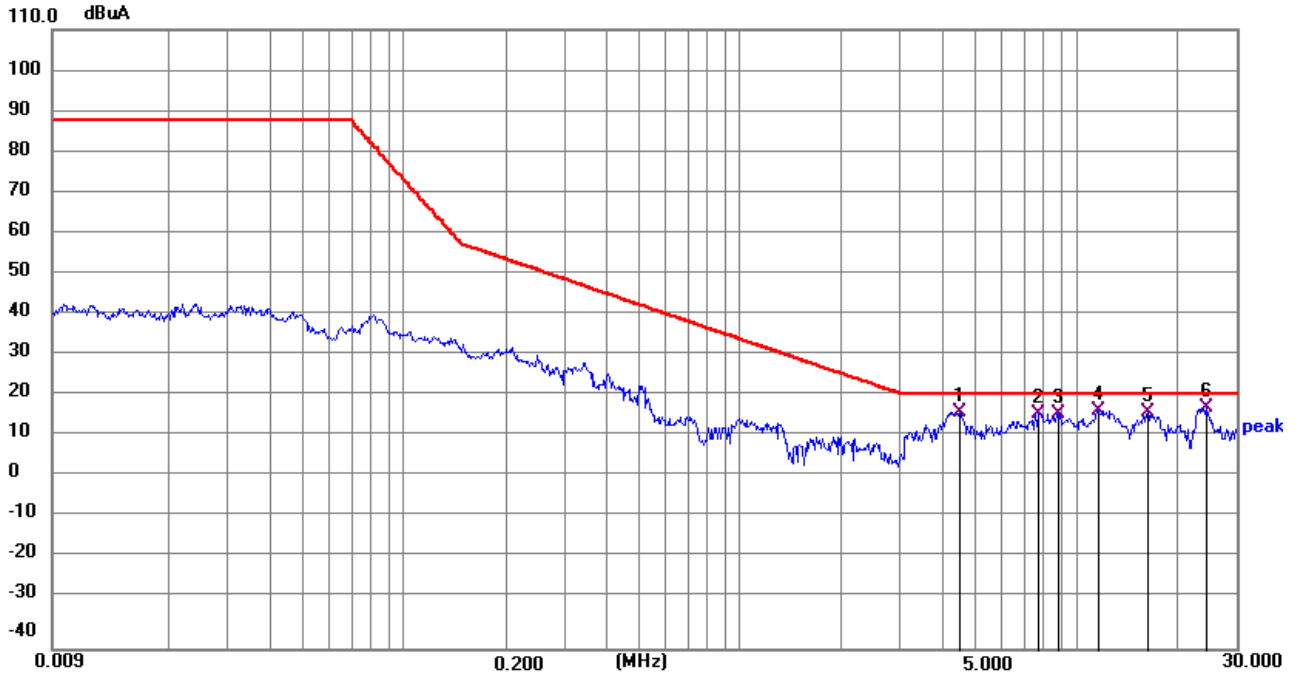

No.	Frequency (MHz)	Reading (dBuA)	Correct Factor (dB)	Results (dBuA)	Limit (dBuA)	Margin (dB)	Detector
1	4.5285	9.43	8.16	17.59	22.00	-4.41	QP
2	7.7865	8.82	8.41	17.23	22.00	-4.77	QP
3	8.8978	8.21	8.97	17.18	22.00	-4.82	QP
4	11.7285	9.15	8.62	17.77	22.00	-4.23	QP
5	16.4310	11.31	6.14	17.45	22.00	-4.55	QP
6	24.3689	12.53	5.85	18.38	22.00	-3.62	QP

Remark:

1. All readings are Quasi-Peak
2. Margin = Result (Result = Reading + Factor)–Limit
3. Factor = Insertion loss + Cable loss

3.3 HARMONICS CURRENT

3.3.1 LIMITS OF THE HARMONICS CURRENT

Harmonic Current Test Limit(C)

Harmonic order (n)	Maximum permissible harmonic current Expressed as a percentage of the input Current at the fundamental frequency %
2	2
3	$30.\lambda$
5	10
7	7
9	5
$15 \leq n \leq 39$ (odd harmonics only)	3
Remark: λ is the circuit power factor	

3.3.2 TEST PROCEDURE

- a. The EUT was placed on the top of a wooden table 0.8 meters above the ground and operated to produce the maximum harmonic components under normal operating conditions.
- b. The classification of EUT is according to section 5 of EN 61000-3-2. The EUT is classified as follows:
 Class A: Balanced three-phase equipment, Household appliances excluding equipment as Class D, Tools excluding portable tools, Dimmers for incandescent lamps, audio equipment, equipment not specified in one of the three other classes.
 Class B: Portable tools. Portable tools.; Arc welding equipment which is not professional equipment.
 Class C: Lighting equipment.
 Class D: Equipment having a specified power less than or equal to 600W of the following types: Personal computers and personal computer monitors and television receivers.
- c. The correspondent test program of test instrument to measure the current harmonics emanated from EUT is chosen. The measure time shall be not less than the time necessary for the EUT to be exercised.

3.3.3 EUT OPERATING CONDITIONS

The EUT tested system was configured as the statements of 2.3 Unless otherwise a special operating condition is specified in the following during the testing.

3.3.4 TEST SETUP

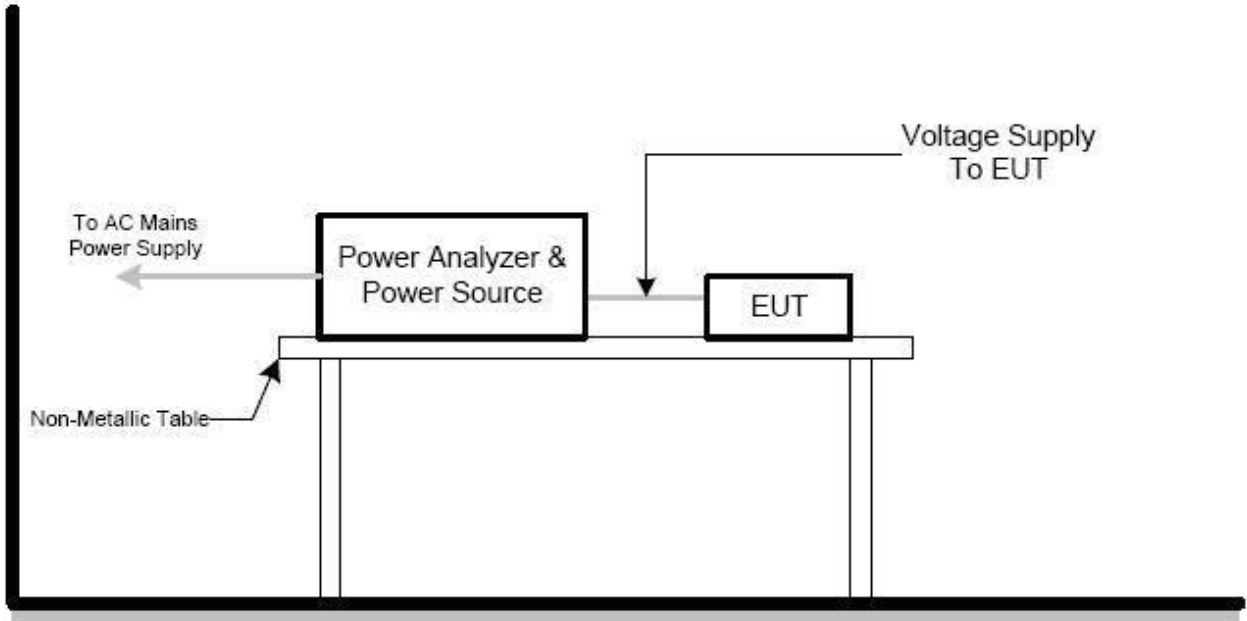

3.3.5 TEST RESULTS

PASS

Please refer to the following page.



Temperature:	24.4°C	Relative Humidity:	45%
Test Voltage:	AC 230V/50Hz	Test Date:	2025.04.24

Test duration (sec):150

Describe:

Test Result: **Pass**

Source qualification(Power On Load): **Idle - Pass**

THC(mA): 8.270

I - THD(%): 8.5

POHC(mA):4.540

POHC Limit(mA):8.954

Parameter values during test:

V_RMS (Volts): 230.2

Frequency(Hz): 50.0

I_RMS(A): 0.78

Crest Factor: 1.489

Power (Watts): 99.1

Power Factor: 2.97

Harm#	Harms(filtered) (mA)	Limit (mA)	Harms(avg) (mA)	100%Limit	Harms(max) (mA)	150%Limit	Status
I_Fund	115.900						
2	0.380	-	0.400	-	0.410	-	N/A
3	2.940	84.660	3.000	3.544	3.050	2.402	Pass
4	0.140	-	0.100	-	0.140	-	N/A
5	1.890	47.310	1.900	4.016	1.910	2.691	Pass
6	0.100	-	0.100	-	0.110	-	N/A
7	0.840	24.900	0.800	3.213	0.850	2.276	Pass
8	0.120	-	0.100	-	0.130	-	N/A
9	1.150	12.450	1.200	9.639	1.210	6.479	Pass
10	0.080	-	0.100	-	0.080	-	N/A
11	1.120	8.715	1.100	12.622	1.130	8.644	Pass
12	0.100	-	0.100	-	0.100	-	N/A
13	0.950	7.374	1.000	13.561	1.000	9.040	Pass
14	0.100	-	0.100	-	0.110	-	N/A
15	2.860	6.391	2.900	45.376	2.880	30.042	Pass
16	0.080	-	0.100	-	0.080	-	N/A
17	1.870	5.639	1.900	33.693	1.920	22.699	Pass
18	0.080	-	0.100	-	0.100	-	N/A
19	0.350	5.046	0.300	5.946	0.350	4.625	Pass
20	0.070	-	0.100	-	0.080	-	N/A
21	0.790	4.565	0.800	17.525	0.800	11.683	Pass
22	0.110	-	0.100	-	0.120	-	N/A
23	1.490	4.168	1.500	35.988	1.610	25.751	Pass
24	0.110	-	0.100	-	0.120	-	N/A
25	2.520	3.835	2.600	67.804	2.590	45.029	Pass
26	0.110	-	0.100	-	0.110	-	N/A
27	1.830	3.551	1.900	53.513	1.930	36.238	Pass
28	0.100	-	0.100	-	0.100	-	N/A
29	1.530	3.306	1.600	48.401	1.570	31.663	Pass
30	0.080	-	0.100	-	0.080	-	N/A
31	1.320	3.092	1.300	42.038	1.330	28.672	Pass
32	0.080	-	0.100	-	0.100	-	N/A
33	0.930	2.905	0.900	30.981	0.940	21.572	Pass
34	0.150	-	0.200	-	0.160	-	N/A
35	0.230	2.739	0.200	7.302	0.250	6.085	Pass
36	0.210	-	0.200	-	0.220	-	N/A
37	0.740	2.591	0.700	27.017	0.750	19.298	Pass
38	0.080	-	0.100	-	0.100	-	N/A
39	1.000	2.458	1.000	40.682	1.010	27.393	Pass
40	0.100	-	0.100	-	0.100	-	N/A

Note: All harmonics are below the minimum limits and are ignored.

3.4 VOLTAGE FLUCTUATION AND FLICKERS

3.4.1 LIMITS OF THE VOLTAGE FLUCTUATION AND FLICKERS

Tests	Measurement Value	Limit	Descriptions
	IEC555-3	IEC/EN 61000-3-3	
P_{st}	$\leq 1.0, T_p= 10 \text{ min.}$	$\leq 1.0, T_p= 10 \text{ min.}$	Short Term Flicker Indicator
P_{lt}	N/A	$\leq 0.65, T_p=2 \text{ hr.}$	Long Term Flicker Indicator
$T_{dt(s)}$	$\leq 3\%$	$\leq 3.3\%$	Relative Steady-State V-Chang
$d_{max}(\%)$	$\leq 4\%$	$\leq 4\%$	Maximum Relative V-Chang
$d_c(\%)$	N/A	$\leq 3.3\%$ for $> 500\text{ms}$	Relative V-change Characteristic

3.4.2 TEST PROCEDURE

b. Fluctuation and Flickers Test:

Tests was performed according to the Test Conditions/Assessment of Voltage Fluctuations specified in Clause 5.0/6.0 of IEC555-3 and/or Clause 6.0/4.0 of IEC/EN 61000-3-3 depend on which standard adopted for compliance measurement.

c. All types of voltage fluctuation in this report are assessed by direct measurement using flicker-meter.

3.4.3 EUT OPERATING CONDITIONS

The EUT tested system was configured as the statements of 2.3 Unless otherwise a special operating condition is specified in the following during the testing.

3.4.5 TEST SETUP

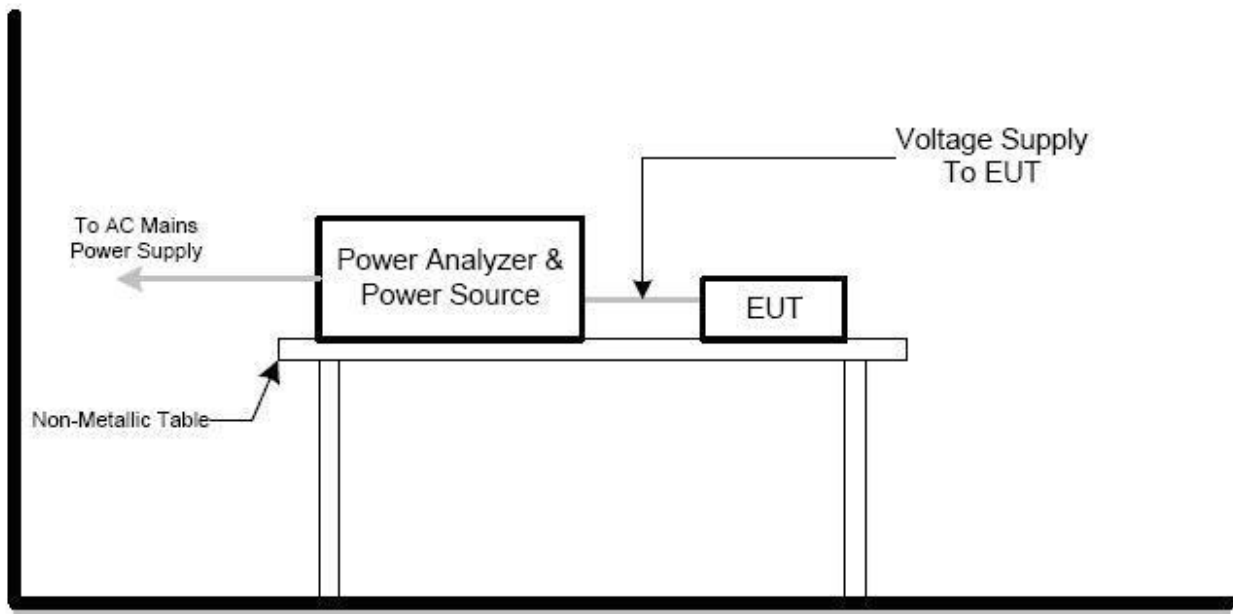

3.3.6 TEST RESULTS

Temperature:	24.2°C	Relative Humidity:	44%
Test Voltage:	AC 230V/50Hz	Test Date:	2025.04.24

Test Parameter	Measurement Value	Limit	Remarks
P _{st}	0.879	1.0	Pass
P _{lt}	--	0.65	--
T _{dt(s)}	0.00	0.5	Pass
d _{max} (%)	-0.53%	4%	Pass
d _c (%)	+0.26%	3.3%	Pass



4. EMC IMMUNITY TEST

4.1 STANDARD COMPLIANCE/SERVRITY LEVEL/CRITERIA

Tests Standard No.	TEST SPECIFICATION	Test Mode Test Ports	Perform. Criteria
1. ESD IEC/EN 61000-4-2	8kV air discharge 4kV contact discharge	Direct Mode	B
	4kV HCP discharge 4kV VCP discharge	Indirect Mode	B
2. RS IEC/EN 61000-4-3	80 MHz to 1000 MHz, 1000Hz, 80%, AM modulated	Enclosure	A
3. EFT/Burst IEC/EN 61000-4-4	5/50ns Tr/Th 5kHz Repetition Freq.	Power Supply Port	B
	5/50ns Tr/Th 5kHz Repetition Freq.	CTL/Signal Data Line Port	B
4. Surges IEC/EN 61000-4-5	1.2/50(8/20) Tr/Th us	L-N	B
	1.2/50(8/20) Tr/Th us	L-PE N-PE	B
5. Injected Current IEC/EN 61000-4-6	0.15 MHz to 80 MHz, 1000Hz 80 % , AM Modulated 150Ω source impedance	CTL/Signal Port	A
	0.15 MHz to 80 MHz, 1000Hz 80 % , AM Modulated 150Ω source impedance	AC Power Port	A
	0.15 MHz to 80 MHz, 1000Hz 80 % , AM Modulated 150Ω source impedance	DC Power Port	A
6. Power Frequency Magnetic Field IEC/EN 61000-4-8	50/60 Hz,	Enclosure	A
7. Volt. Interruptions Volt. Dips IEC/EN 61000-4-11	Voltage dip 100%	AC Power Port	B
	Voltage dip 30%		C

4.2 GENERAL PERFORMANCE CRITERIA

According to **EN 61547** standard, the general performance criteria as following:

Criterion A	During the test, no change of the luminous intensity shall be observed and the regulating control, if any, shall operate during the test as intended.
Criterion B	During the test, the luminous intensity may change to any value. After the test, the luminous intensity shall be restored to its initial value within 1 min. Regulating controls need not function during the test, but after the test, the mode of the control shall be the same as before the test provided that during the test no mode changing commands were given.
Criterion C	During and after the test, any change of the luminous intensity is allowed and the lamp(s) may be extinguished. After the test, within 30 min, all functions shall return to normal, if necessary by temporary interruption of the mains supply and/or operating the regulating control. Additional requirement for lighting equipment incorporating a starting device: After the test, the lighting equipment is switched off. After half an hour, it is switched on again. The lighting equipment shall start and operate as intended.

4.2.1 GENERAL PERFORMANCE CRITERIA TEST SETUP

The EUT tested system was configured as the statements of **2.3** Unless otherwise a special operating condition is specified in the following during the testing.

4.3 ELECTROSTATIC DISCHARGE IMMUNITY TEST (ESD)

4.3.1 TEST SPECIFICATION

Basic Standard:	IEC/EN 61000-4-2
Discharge Impedance:	330 ohm / 150 pF
Required Performance:	B
Discharge Voltage:	Air Discharge: 2kV/4kV/8kV (Direct) Contact Discharge: 2kV/4kV (Direct/Indirect)
Polarity:	Positive & Negative
Number of Discharge:	Air Discharge: min. 20 times at each test point Contact Discharge: min. 20 times in total
Discharge Mode:	Single Discharge
Discharge Period:	1 second minimum

4.3.2 TEST PROCEDURE

The test generator necessary to perform direct and indirect application of discharges to the EUT in the following manners:

- a. Vertical Coupling Plane (VCP):
The coupling plane of dimensions 0.5m x 0.5m, is placed parallel to and positioned at a distance 0.1m from the EUT, with the Discharge Electrode touching the coupling plane. The four faces of the EUT will be performed with electrostatic discharge.
- Horizontal Coupling Plane (HCP):
The coupling plane is placed under to the EUT. The generator shall be positioned vertically at a distance of 0.1m from the EUT, with the Discharge Electrode touching the coupling plane. The four faces of the EUT will be performed with electrostatic discharge.
- b. Air discharges at insulation surfaces of the EUT.
It was at least ten single discharges with positive and negative at the same selected point.

4.3.3 TEST SETUP

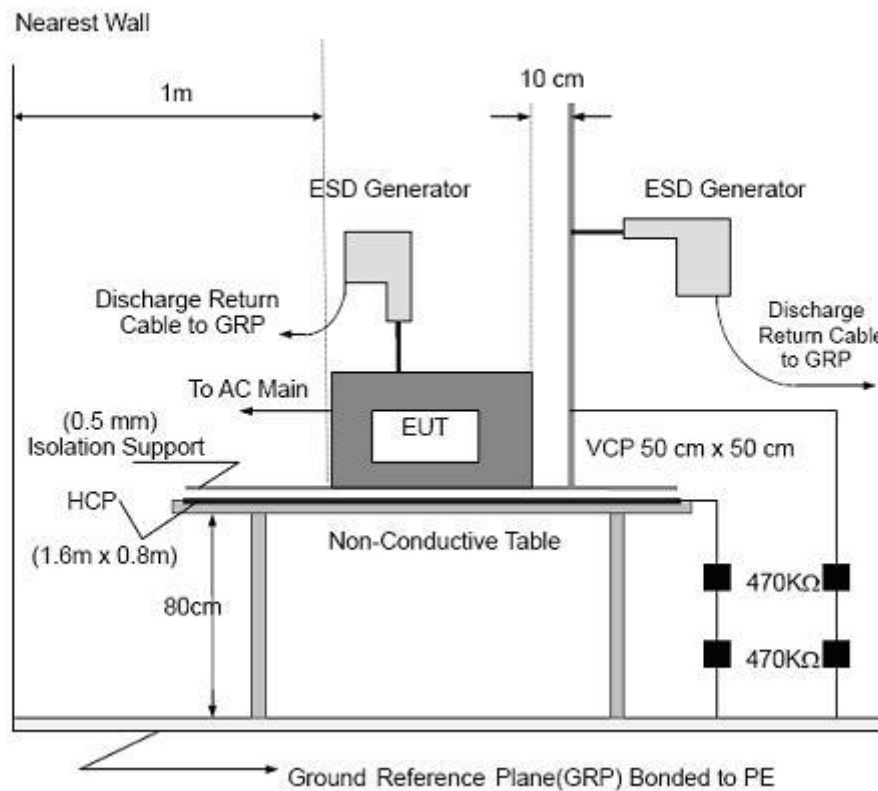

Note:

TABLE-TOP EQUIPMENT

The configuration consisted of a wooden table 0.8 meters high standing on the Ground Reference Plane. The GRP consisted of a sheet of aluminum at least 0.25mm thick. A Horizontal Coupling Plane (1.6m x 0.8m) was placed on the table and attached to the GRP by means of a cable with 940kΩ total impedance. The equipment under test, was installed in a representative system as described in section 7 of IEC /EN 61000-4-2, and its cables were placed on the HCP and isolated by an insulating support of 0.5mm thickness. A distance of 0.8-meter minimum was provided between the EUT and the walls of the laboratory and any other metallic structure.

FLOOR-STANDING EQUIPMENT

The equipment under test was installed in a representative system as described in section 7 of IEC/EN 61000-4-2, and its cables were isolated from the Ground Reference Plane by an insulating support of 0.1 meter thickness. The GRP was consisted of a sheet of aluminum that is at least 0.25mm thick, and extended at least 0.5 meters from the EUT on all sides.

4.3.4 TEST RESULTS

Temperature:	24.2°C	Relative Humidity:	49%
Pressure:	1025hPa	Test Voltage:	AC 230V 50Hz
Test Mode:	Mode 1	Test Date:	2025.04.24

Discharge Level	Polarity	Test Points	Contact Discharge	Air Discharge	Criterion	Test Result
4	+/-	VCP/HCP	NOTE	N/A	A	PASS
2,4	+/-	Green Dot	NOTE	N/A	A	PASS
2,4,8	+/-	Red Dot	N/A	NOTE	A	PASS

Note: The EUT function was correct during the test
 Red Dot —Air Discharged
 Green Dot —Contact Discharged
 N/A* No such discharge point found.



The Photo for Discharge Points of EUT

– Contact Discharge ● – Air Discharge ●

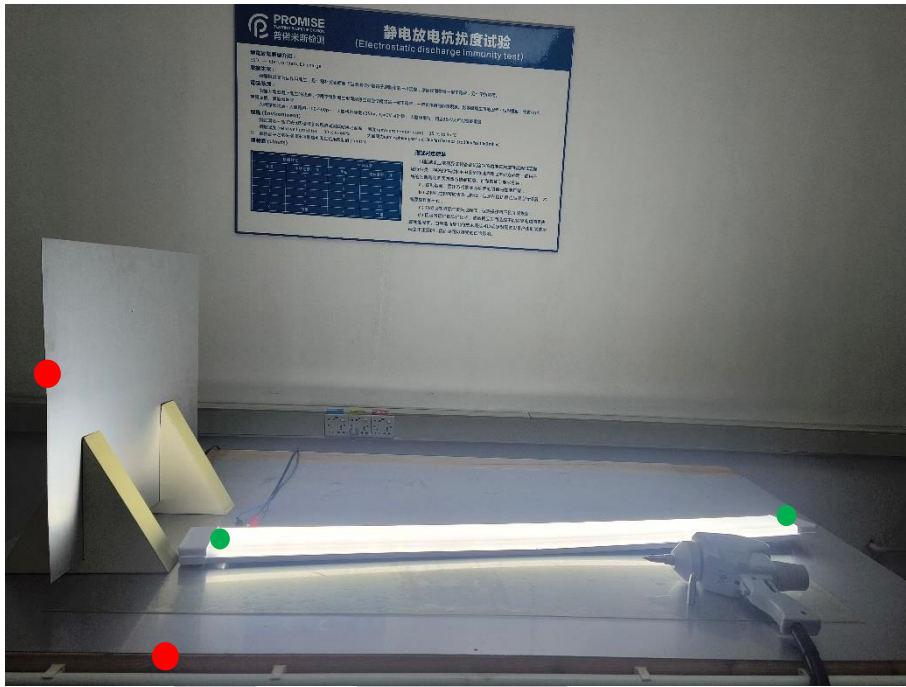

4.4 RADIATED, RADIO-FREQUENCY, ELECTROMAGNETIC FIELD IMMUNITY TEST (RS)

4.4.1 TEST SPECIFICATION

Basic Standard:	IEC/EN 61000-4-3
Required Performance:	A
Frequency Range:	80 MHz - 1000 MHz
Field Strength:	3 V/m
Modulation:	1kHz Sine Wave, 80%, AM Modulation
Frequency Step:	1 % of fundamental
Polarity of Antenna:	Horizontal and Vertical
Test Distance:	3 m
Antenna Height:	1.5 m
Dwell Time:	1.5×10^{-3} decade/s

4.4.2 TEST PROCEDURE

- a. The testing was performed in a fully anechoic chamber. The transmit antenna was located at a distance of 3 meters from the EUT.
- b. The frequency range is swept from 80 MHz to 1000 MHz, with the signal 80% amplitude modulated with a 1kHz sine-wave. The rate of sweep did not exceed 1.5×10^{-3} decade/s, where the frequency range is swept incrementally, the step size was 1% of preceding frequency value.
- c. The dwell time at each frequency shall be not less than the time necessary for the EUT to be able to respond.
- e. The test was performed with the EUT exposed to both vertically and horizontally polarized fields on each of the four sides.

4.4.3 TEST SETUP

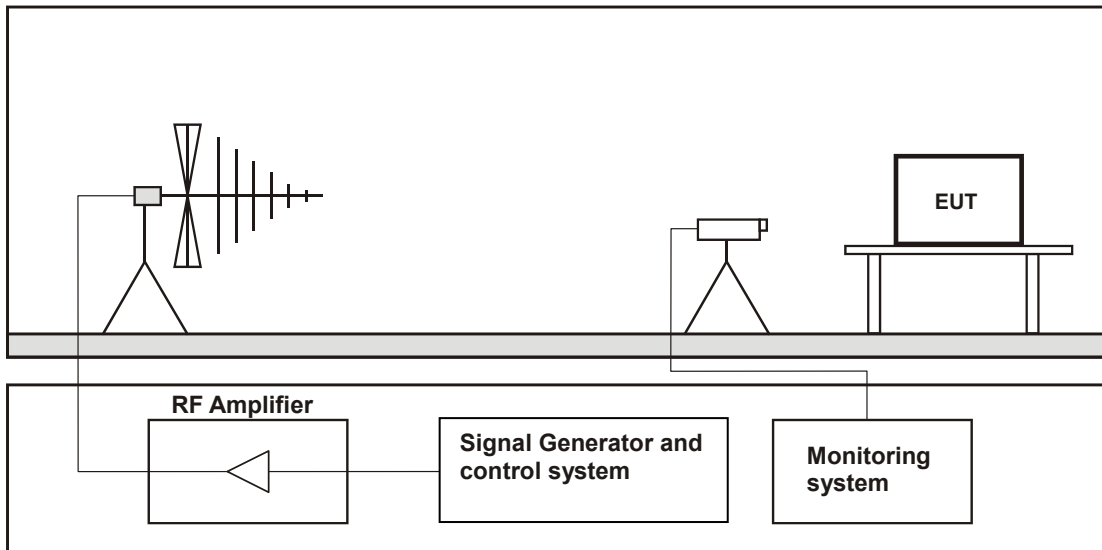

Note:

TABLE-TOP EQUIPMENT

The EUT installed in a representative system as described in section 7 of IEC/EN 61000-4-3 was placed on a non-conductive table 0.8 meters in height. The system under test was connected to the power and signal wire according to relevant installation instructions.

FLOOR-STANDING EQUIPMENT

The EUT installed in a representative system as described in section 7 of IEC/EN 61000-4-3 was placed on a non-conductive wood support 0.1 meters in height. The system under test was connected to the power and signal wire according to relevant installation instructions.

4.4.4 TEST RESULTS

Temperature:	24.6°C	Relative Humidity:	48%
Test Voltage:	AC 230V 50Hz	Test Date:	2025.04.25
Test Mode:	Mode 1		

Frequency Range (MHz)	RF Field Position	R.F. Field Strength	Azimuth	Perform. Criteria	Results	Judgment
80MHz - 1000MHz	H / V	3 V/m (rms) AM Modulated 1000Hz, 80%	Front	A	A	PASS
			Rear			
			Left			
			Right			



4.5 ELECTRICAL FAST TRANSIENT (EFT)

4.5.1 TEST SPECIFICATION

Basic Standard:	IEC/EN 61000-4-4
Required Performance:	B
Test Voltage:	Power Line: 1 kV Signal/Control Line: 0.5 kV
Polarity:	Positive & Negative
Impulse Frequency:	5 kHz
Impulse Wave shape :	5/50 ns
Burst Duration:	15ms
Burst Period:	300ms
Test Duration:	Not less than 2 min.

4.5.2 TEST PROCEDURE

The EUT and support units were located on a wooden table 0.8m&0.1m away from ground reference plane. A 1.0 meter long power cord was attached to EUT during the test.

- a. The length of power cord between the coupling device and the EUT should not exceed 1 meter.
- b. Both positive and negative polarity discharges were applied.
- c. The duration time of each test sequential was 2 minute.

4.5.3 TEST SETUP

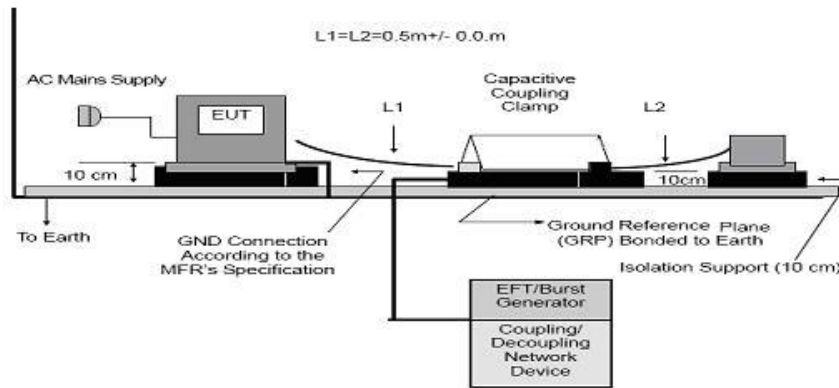
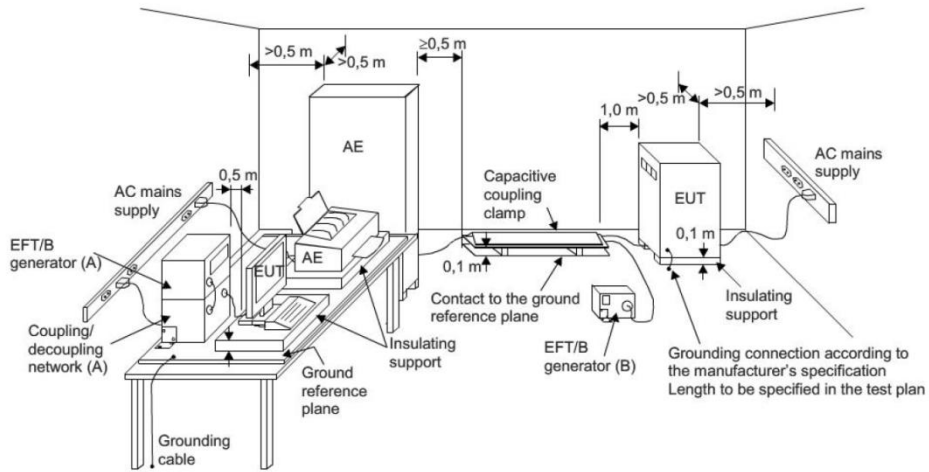

Note:

TABLE-TOP EQUIPMENT

Table-top equipment and equipment normally mounted on ceilings or walls as well as built-in equipment shall be tested with the EUT located (0.1 ± 0.01) m above the ground reference plane.

Testing of large table-top equipment or multiple systems can be performed on the floor; maintaining the same distances as for the test setup of table-top equipment.

The test generator and the coupling/decoupling network shall be bonded to the ground reference plane.

The ground reference plane shall be a metallic sheet (copper or aluminum) of 0.25mm minimum thickness; other metallic materials may be used, but they shall have at least 0.65 mm minimum thickness.

The minimum size of the ground reference plane is 0.8m x 1m. The actual size depends on the dimensions of the EUT.

The ground reference plane shall project beyond the EUT by at least 0.1m on all sides.

The ground reference plane shall be connected to the earth (PE) for safety reasons.

The EUT shall be arranged and connected to satisfy its functional requirements, according to the equipment installation specifications.

The minimum distance between the EUT and all other conductive structures (including the generator, AE and the walls of a shielded room), except the ground reference plane, shall be more than 0.5m.

All cables to the EUT shall be placed on the insulation support 0.1m above the ground reference plane. Cables not subject to electrical fast transients shall be routed as far as possible from the cable under test to minimize the coupling between the cables.

The EUT shall be connected to the earth system in accordance with the manufacturer's installation specifications; no additional earth connections are allowed.

The connection impedance of the coupling/decoupling network earth cables to the ground reference plane and all connectors shall provide a low inductance.

Either a direct coupling network or a capacitive clamp shall be used for the application of the test voltages. The test voltages shall be coupled to all of the EUT ports in turn including those between two units of equipment involved in the test, unless the length of the interconnecting cable makes it impossible to test.

FLOOR-STANDING EQUIPMENT

When using the coupling clamp, the minimum distance between the coupling plates and all other conductive surfaces (including the generator), except the ground reference plane beneath the coupling clamp and beneath the EUT, shall be at least 0.5m.

The distance between any coupling devices and the EUT shall be $(0.5 - 0/+0.1)$ m for tabletop equipment testing, and (1.0 ± 0.1) m for floor standing equipment, unless otherwise specified in product standards. When it is not physically possible to apply the distances mentioned above, other distances can be used and shall be recorded in the test report.

The cable between the EUT and the coupling device, if detachable, shall be as short as possible to comply with the requirements of this clause. If the manufacturer provides a cable exceeding the distance between the coupling device and the point of entry of the EUT, the excess length of this cable shall be bundled and situated at a distance of 0.1m above the ground reference plane.

When a capacitive clamp is used as a coupling device, the excess cable length shall be bundled at the AE side.

Parts of the EUT with interconnecting cables of a length less than 3m, which are not tested, shall be placed on the insulating support. The parts of the EUT shall have a distance of 0.5m between them. Excess cable length shall be bundled.

4.5.4 TEST RESULTS

Temperature:	24.8°C	Relative Humidity:	49%
Test Voltage:	AC 230V 50Hz	Test Date:	2025.04.25
Test Mode:	Mode 1		

Coupling Line		Test level	Perform. Criteria	Results	Judgment
AC line	L	± 1kV	B	A	PASS
	N	± 1kV		A	PASS
	PE	N/A		N/A	N/A
	L+N	± 1kV		A	PASS
	L+PE	N/A		N/A	N/A
	N+PE	N/A		N/A	N/A
	L+N+PE	N/A		N/A	N/A
DC Line		N/A		N/A	N/A
Signal Line		N/A		N/A	N/A

Note: 1) N/A - denotes test which is not applicable in this test report.

4.6 SURGE TESTING

4.6.1 TEST SPECIFICATION

Basic Standard:	IEC/EN 61000-4-5
Required Performance:	B
Wave-Shape:	Combination Wave 1.2/50µs Open Circuit Voltage
Test Voltage:	See below Table 1
Surge Input/Output:	L-N, L-PE, N-PE
Generator Source:	(L-N)2 ohm between networks
Impedance:	(L-PE, N-PE)12 ohm between network and ground
Polarity:	Positive/Negative
Phase Angle:	0°/90°/180°/270°
Pulse Repetition Rate:	1 time / min. (maximum)
Number of Tests:	5 positive and 5 negative at selected points

Table 1: Test Levels at input a. c. power ports

Characteristics	Test levels		
	Device		
	Self-ballasted lamps and semi-luminaires	Luminaires and independent auxiliaries	
		Input power	
	≤25W	>25W	
Wave-shape data	1,2/50	1,2/50µs	1,2/50µs
Test levels line to line	±0.5 kV	±0.5 kV	±1.0 kV
Line to ground	±1.0 kV	±1.0 kV	±2.0 kV

4.6.2 TEST PROCEDURE

- a. For EUT power supply:
The surge is to be applied to the EUT power supply terminals via the capacitive coupling network. Decoupling networks are required in order to avoid possible adverse effects on equipment not under test that may be powered by the same lines, and to provide sufficient decoupling impedance to the surge wave. The power cord between the EUT and the coupling/decoupling networks shall be 2 meters in length (or shorter).
- b. For test applied to unshielded unsymmetrical operated interconnection lines of EUT:
The surge is applied to the lines via the capacitive coupling. The coupling /decoupling networks shall not influence the specified functional conditions of the EUT. The interconnection line between the EUT and the coupling/decoupling networks shall be 2 meters in length (or shorter).

4.6.3 TEST SETUP

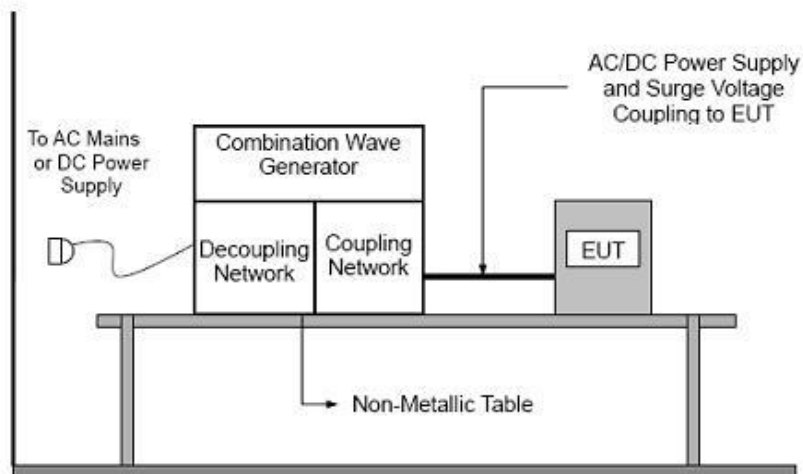

4.6.4 TEST RESULTS

Temperature:	25.2°C	Relative Humidity:	49%
Test Voltage:	AC 230V 50Hz	Test Date:	2025.04.25
Test Mode:	Mode 1		

Coupling Line		Test level	Perform. Criteria	Results	Judgment
AC line	L-N	± 1kV	B	A	PASS
	L-PE	N/A		N/A	N/A
	N-PE	N/A		N/A	N/A
DC Line		N/A		N/A	N/A
Signal Line		N/A		N/A	N/A

Note: 1) N/A - denotes test which is not applicable in this test report.



4.7 CONDUCTED RADIO FREQUENCY DISTURBANCES (CS)

4.7.1 TEST SPECIFICATION

Basic Standard:	IEC/EN 61000-4-6
Required Performance:	A
Frequency Range:	0.15 MHz - 80 MHz
Field Strength:	3Vr.m.s.
Modulation:	1kHz Sine Wave, 80%, AM Modulation
Frequency Step:	1 % of fundamental
Dwell Time:	1.5×10^{-3} decade/s

4.7.2 TEST PROCEDURE

The EUT shall be tested within its intended operating and climatic conditions.

The test shall be performed with the test generator connected to each of the coupling and decoupling devices in turn, while the other non-excited RF input ports of the coupling devices are terminated by a 50-ohm load resistor.

The frequency range was swept from 150 kHz to 80 MHz, using the signal level established during the setting process and with a disturbance signal of 80 % amplitude. The signal was modulated with a 1 kHz sine wave, pausing to adjust the RF signal level or the switch coupling devices as necessary. The sweep rate was 1.5×10^{-3} decades/s. Where the frequency range is swept incrementally, the step size was 1 % of preceding frequency value from 150kHz to 80MHz.

The dwell time at each frequency was less than the time necessary for the EUT to be exercised, and able to respond. Sensitive frequencies such as clock frequency (ies) and harmonics or frequencies of dominant interest, was analyzed separately.

Attempts were made to fully exercise the EUT during testing, and to fully interrogate all exercise modes selected for susceptibility.

4.7.4 TEST RESULTS

Temperature:	24.9°C	Relative Humidity:	48%
Test Voltage:	AC 230V 50Hz	Test Date:	2025.04.25
Test Mode:	Mode 1		

Test Ports (Mode)	Freq. Range (MHz)	Field Strength	Perform. Criteria	Results	Judgment
Input/ Output AC. Power Port	0.15 - 80	3V(rms) AM Modulated 1000Hz, 80%	A	A	PASS
Input/ Output DC. Power Port	0.15 - 80		N/A	N/A	N/A
Signal Line	0.15 - 80		N/A	N/A	N/A

Note: 1) N/A - denotes test which is not applicable in this test report.



4.8 VOLTAGE INTERRUPTION/DIPS TESTING (DIPS)

4.8.1 TEST SPECIFICATION

Basic Standard:	IEC/EN 61000-4-11
Required Performance:	B (For 100% Voltage Dips, 0.5 Cycle) C (For 30% Voltage Dips, 10 Cycles)
Test Duration Time:	Minimum three test events in sequence
Interval between Event:	Minimum ten seconds
Phase Angle:	0°/45°/90°/135°/180°/225°/270°/315°/360°
Test Cycle:	3 times

4.8.2 TEST PROCEDURE

The EUT shall be tested for each selected combination of test levels and duration with a sequence of three dips/interruptions with intervals of 10 s minimum (between each test event). Each representative mode of operation shall be tested. Abrupt changes in supply voltage shall occur at zero crossings of the voltage waveform.

4.8.3 TEST SETUP

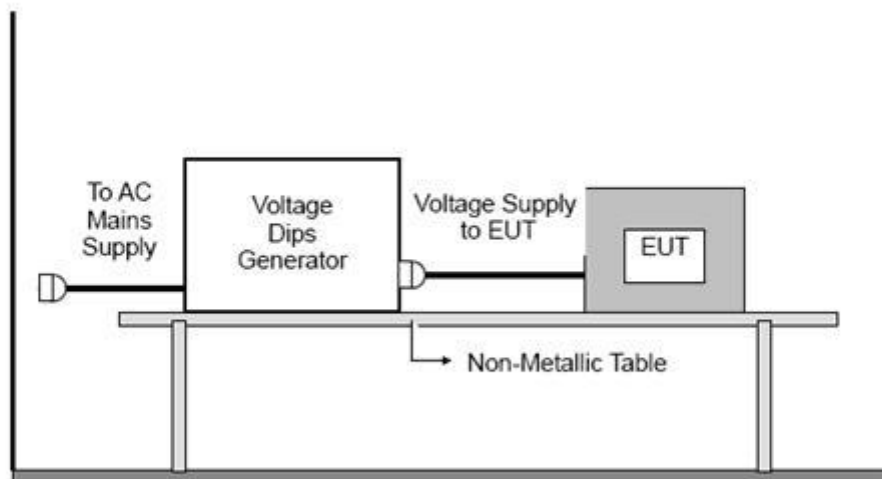

4.8.4 TEST RESULTS

Temperature:	24.2℃	Relative Humidity:	49%
Test Voltage:	AC 230V 50Hz	Test Date:	2025.04.25
Test Mode:	Mode 1		

Voltage Reduction	Duration (cycle)	Perform Criteria	Results	Judgment
Voltage dip 100%	0.5	B	B	PASS
Voltage dip 30%	10	C	B	PASS



APPENDIX 1- TEST SETUP

Radiated Measurement Photo

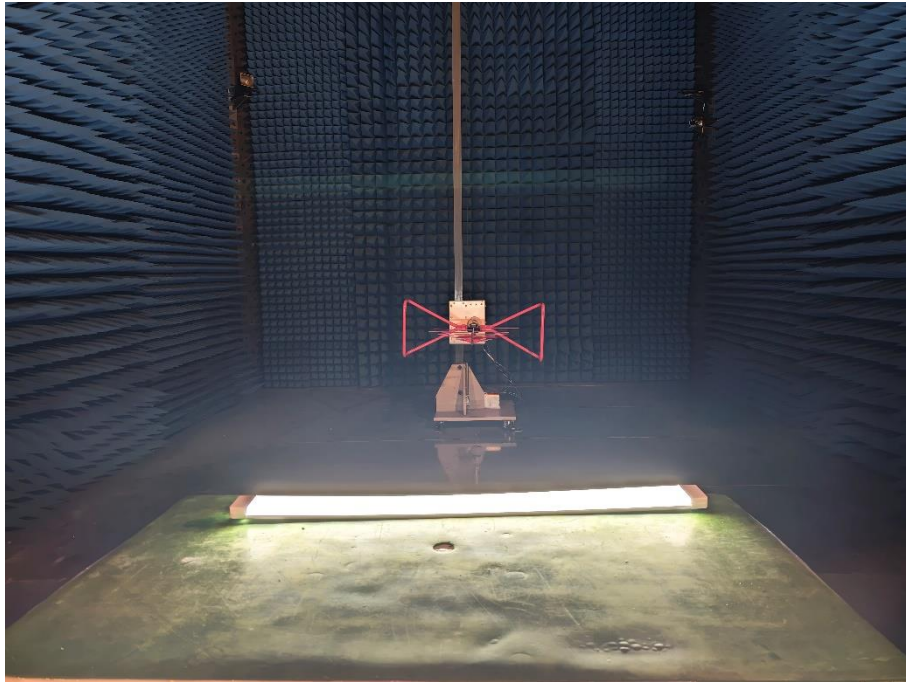

Conducted Emission

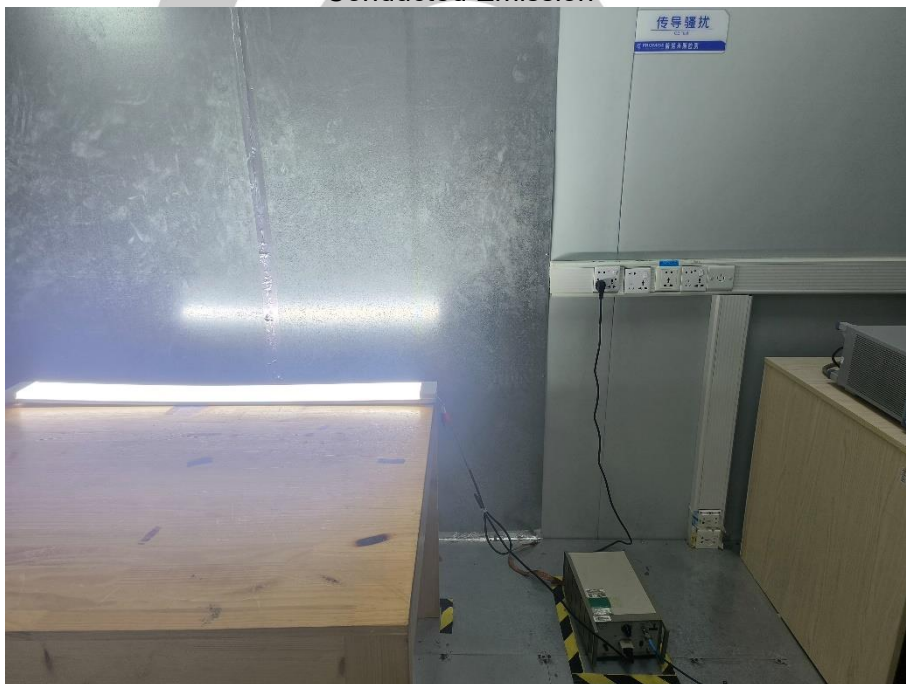

ESD Measurement Photo

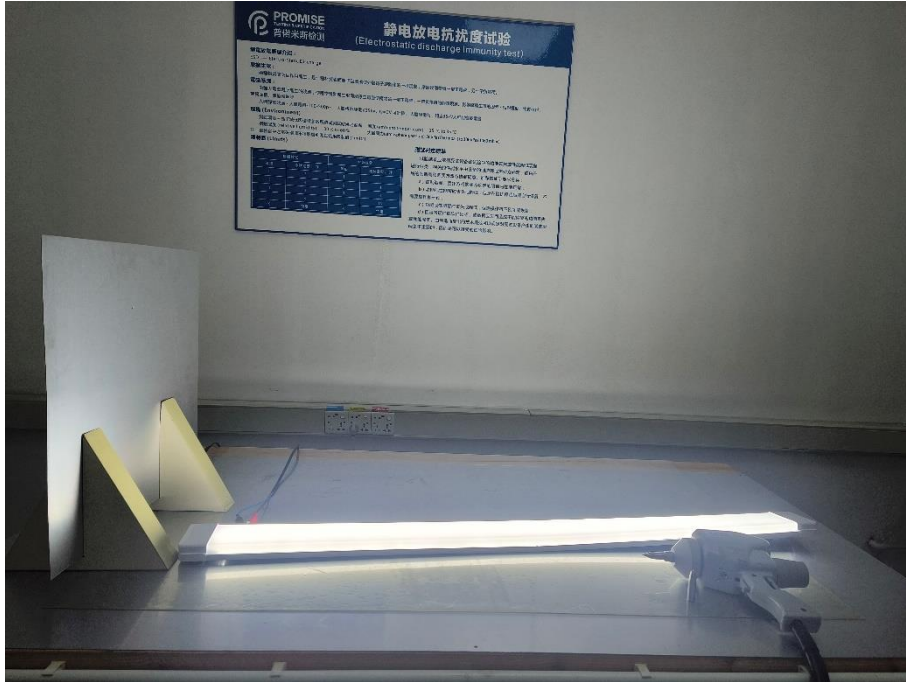

EFT Measurement Photo



SURGE Measurement Photo



DIPS Measurement Photo



APPENDIX 2-PHOTOGRAPHS OF EUT CONSTRUCTIONAL DETAILS

Photo 1



Photo 2



Photo 3

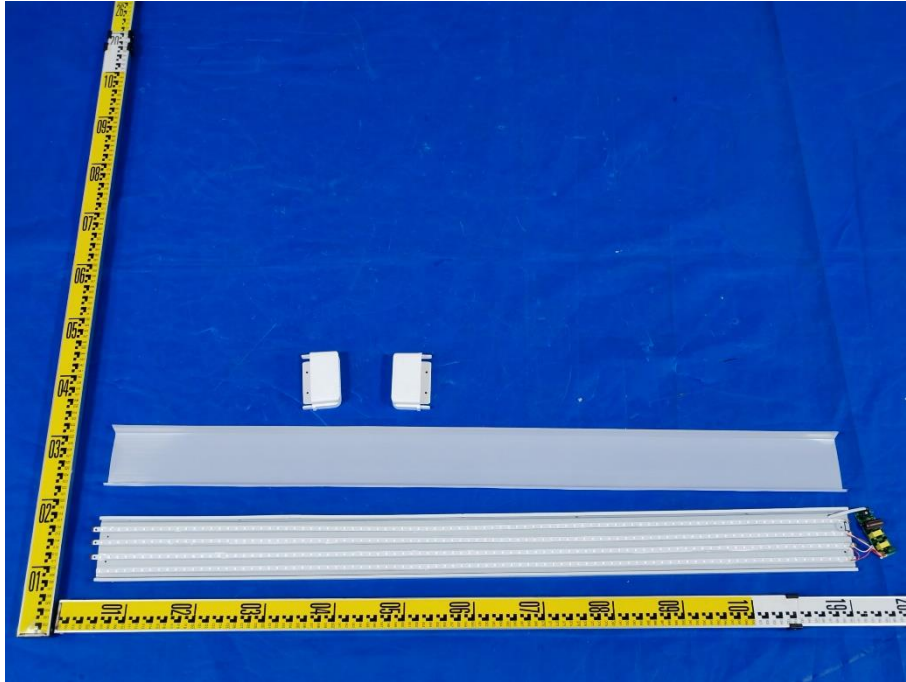

Photo 4

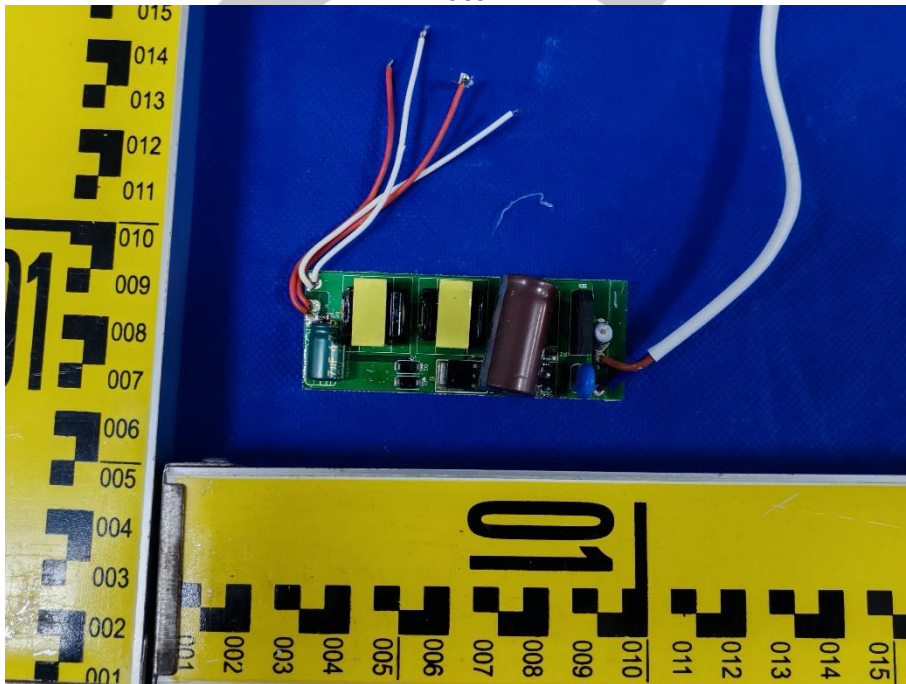
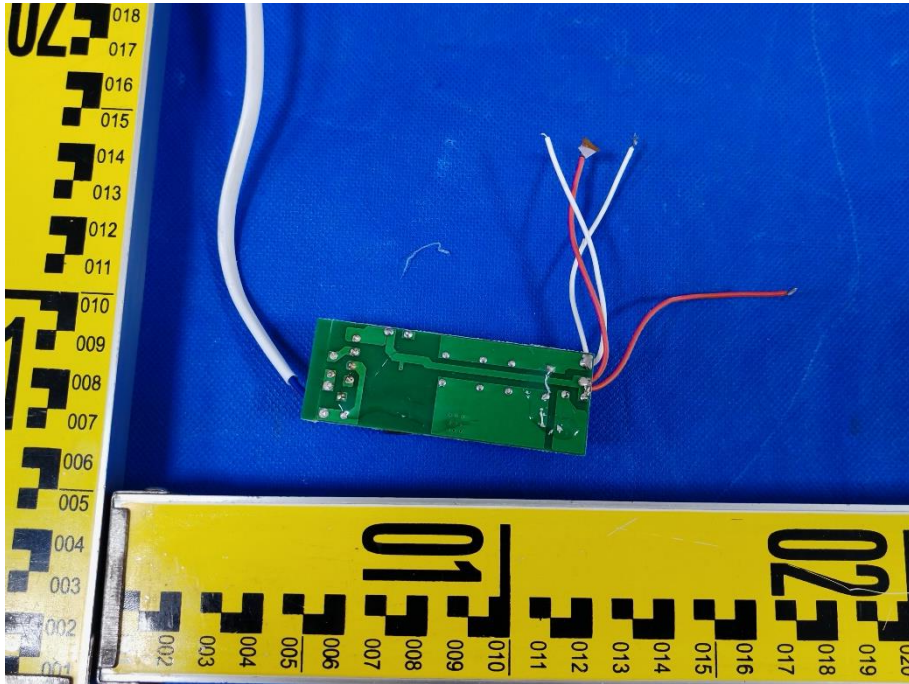

Photo 5



XXXXXXXXXX**END OF THE REPORT**XXXXXXXXXX

